

# SIEMENS DI-3, DI-A3 and DI-B3 Ionization Smoke Detector

Fire Safety

## ENGINEER AND ARCHITECT SPECIFICATIONS

- Adjustable Sensitivity
- Dual Chamber
- Sensitivity Test Points
- Simple Twist/Lock Assembly
- Optional Auxiliary Relay
- Screw-Clamp Terminals
- Alarm LED
-  Listed, ULC Listed, NYMEA, FM, CSFM Approved

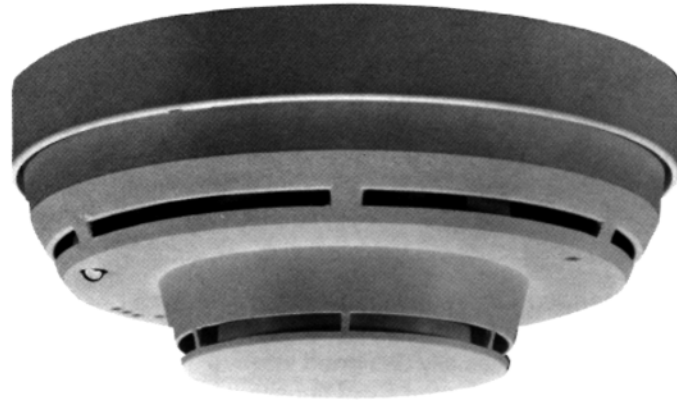

### Introduction

The Siemens Building technologies, Fire Safety Division DI-3, DI-A3 and DI-B3 fire smoke detectors operate on the ionization principle. The detectors respond to the first traces of fire in the form of visible smoke or invisible products of combustion. The DI-3, DI-A3 and DI-B3 have been developed for the wide range of commercial, industrial and institutional fire detection and extinguishing applications. The DI-3, DI-A3 and DI-B3 are approved in environments covered by UL 268 & UL 268A. The DI-B3 must be utilized with a Series 3™ air duct housing.

### Description

The DI-3 Series detector is a plug-in, ionization detector and is designed for two wire system operation. The DI-3 is designed with adjustable sensitivity while the DI-A3 and the DI-B3 have a fixed sensitivity designed for their individual high air flow applications.

The DI-3, DI-A3 and DI-B3 consist of self-compensating dual ionization chambers and a highly stable solid state amplifier-switching circuit. One chamber detects the presence of combustion products, the second chamber serves as a reference, to stabilize the detector's sensitivity for changes in environmental conditions. As products of combustion enter the sampling chamber, the chamber current is reduced producing a voltage change. At the time the voltage range exceeds the pre-determined

threshold, an alarm is signaled to the control unit. The detector locks in upon alarm and must be reset from the control panel.

The sensitivity of the DI-3, DI-A3 and DI-B3 is preset at the factory. The electrical sensitivity can be monitored in the field using the Fire Safety sensitivity tester, test module TM-I3. The sensitivity test jack on the DI-3, DI-A3 and DI-B3 and the adjustment screw on the DI-3 are accessible from the front of the detector housing enabling the user to perform all sensitivity adjustments and tests without removing the detector from its base.

The detectors utilize a low profile surface mounting base, model DB-3S, which may be attached to either a 4" octagonal, single gang outlet box or 4" square wiring box — or the audible base model ADB-3, which must be attached to a 4" square, deep wiring box. The DB-3S base and ADB-3 audible base utilize screw-clamp terminals for all electrical connections, self-wiping contacts for reliability and contain provision for an optional concealed locking mechanism to prevent unauthorized removal of the detector head.

The DI-3 Series ionization detector has been designed to meet a wide range of system design parameters. The DI-3 detector is designed for open area protection in areas with air velocities up to 300 feet per minute.

CATALOG NUMBER **6119**

  
Your Portal to the Industrial World

**IndustrialZone**  
P.O. Box 667306  
Houston, Texas 77266  
United States

(713)-395-1508  
Fax: (713) 893-6924  
support@industrialzone.com  
[www.industrialzone.com](http://www.industrialzone.com)

## Mounting Data

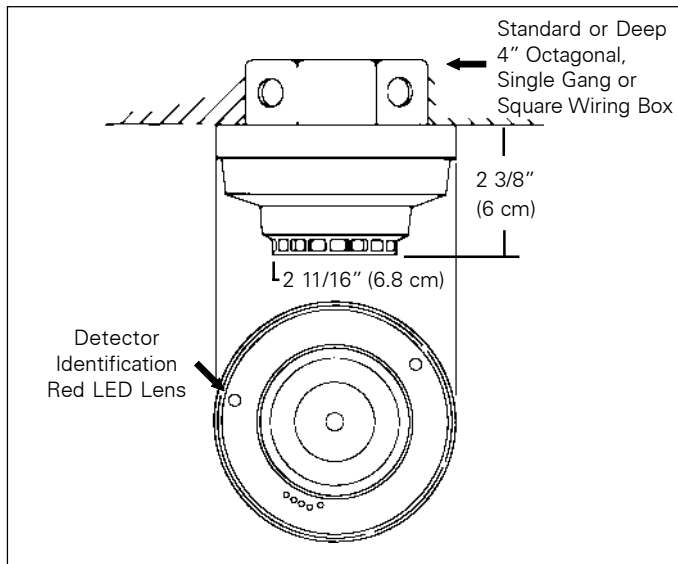

DI-A3 is recommended for use in high air velocity applications such as computer room underfloor areas. The model DI-A3 contains a specially designed internal chamber cover and a pre-selected fixed sensitivity setting which provides extremely stable operation. Model DI-A3 has been UL listed for operation in air velocities of 0 to 1200 feet per minute. Since air velocity has an effect on detector sensitivity and performance, the DI-A3 should be used only in applications which meet this established air velocity range.

The DI-B3 is designed specifically for use with the Fire Safety Series 3 air duct housings and, like the DI-A3, contains a specially designed internal chamber cover and a pre-selected fixed sensitivity setting. The DI-B3 must be utilized with the Series 3 air duct housing in air duct applications with air velocities of 500-4000 FPM.

The DI-3, DI-A3 and DI-B3 are also available for high altitude applications, (3000 to 8000 feet above sea level) as model numbers DI-3H, DI-A3H and DI-B3H.

The DI-3 and DI-A3 are capable of operating a remote alarm lamp, RLI1, RLI2, RL-30, RL-40 or auxiliary relay, model RR-3. The model RR-3/3S relay contains one set of double pole, double throw contacts rated at 120VAC, 2 Amp. Resistive and requires a deep outlet box when mounted to the DB-3S. The DI-B3 is capable of utilizing the remote relay as supplied in the Series 3 air duct housing model AD-3 with a DA-3SR Relay Board which contains one set of double pole, double throw contacts rated at 125 VAC/24 VDC, 3 Amp. Resistive.

When multiple detector/relay combinations are used on the same circuit, the zone module current limit will restrict the number of guaranteed detector/relay actuations to one per zone.

The DI-3, DI-A3, DI-B3, DI-3H, DI-A3H and DI-B3H ionization detectors are Underwriters Laboratories, Inc. Listed. The series is also FM, CSFM and NYMEA approved.

An FM approved, intrinsically safe DI-3 is available under model DI-3IS. The DI-3IS must be utilized with the intrinsically safe System 3 zone module, model ZS-30 or MXL zone module CZM-1/ISI-1.

## Application Data

The DI-3, DI-A3, DI-B3, DI-3H, DI-A3H and DI-B3H detectors are fully compatible with other Fire Safety System 3 compatible detectors and may be intermixed on the same zone circuit. No more than thirty (30) detectors of any type of combination (other than thermals or manual stations) may be used on any one Fire Safety detector circuit.

This detector is applicable to the 30-foot center spacing (900 sq. ft.) as referred to in NFPA 72. This spacing, however, is based on ideal conditions namely, smooth ceiling, no air movement, and no physical obstructions between the fire source and the detector. This spacing should be used as a guide or starting point in the detector installation layout. Do not mount detectors in areas close to ventilating or air conditioning outlets. Exposed joists or beamed ceilings may also affect safe spacing limitations for detectors. It is mandatory that engineering judgment be applied regarding detector location and spacing.

## Engineer and Architect Specifications

The ionization smoke detector shall be a dual chamber plug-in unit which mounts to a twist/lock base and shall be UL listed.

The smoke detector shall operate on a two-wire circuit and shall contain an alarm indicating LED which will illuminate to signal actuation of the detector.

**DI-A3 ONLY** The detector shall be specifically designed for use in high air velocity applications of between 0 and 1200 ft./min. Detectors which are not UL listed for the stated air velocity range shall not be accepted.

**DI-B3 ONLY** The detector shall be specifically designed for use in air ducts with air velocities between 500-4000 FPM when used with Fire Safety Series 3 air duct housings. Detectors not listed to UL 268A for the stated air velocity range shall not be accepted.

The detector shall be available in a model that is acceptable for and UL listed for use in altitudes of 3000-8000 feet above sea level if desired models DI-3H, DI-A3H or DI-B3H.

Field adjustment\* and monitoring of the detector sensitivity shall be possible without removal of the detector head from its base. The measurement of detector sensitivity shall provide a discrete electrical value. Test methods which do not provide an output signal proportional to smoke concentrations shall not be considered equal. The base assembly into which the detector is installed shall be of the twist/lock design with screw-clamp terminals. The base shall utilize self-wiping contacts for reliability and shall accept other compatible plug-in detectors. A security lock shall be installed in those areas where tamper resistant installation is required as indicated on the drawings.

The detector, or group of detectors, shall require a two-wire circuit of #18 AWG thermoplastic fixture wire enclosed in metal raceway, or #18 AWG limited energy shielded cable without conduit, if permitted by local codes.

Optional auxiliary DPDT relays or remote alarm lamps shall be installed where indicated.

The detector assembly shall be a Fire Safety DI (insert number) with DB-3S mounting base, ADB-3 audible or Series 3 air duct housing.\*\*

\*DI-3, DI-3H only

\*\*DI-B3, DI-B3H only

## Technical Specifications

Current Requirements: Normal — 100uA (350uA peak surge upon application of power) Alarm — 80mA

Voltage Range: 21  $\pm$ 3VDC

Operating Temperature: +32°F (0°C) to +100°F (38°C) per UL

Humidity: 0-93% Relative Humidity

Air Velocity: 0-300 ft./min. Model DI-3  
0-1200 ft./min. Model DI-A3  
500-4000 ft./min. Model DI-B3  
(Requires air duct housing)

**Note:** Consult factory for special application requirements. For additional product information, refer to Fire Safety DI-3 technical bulletin, P/N 315-082300.

## Typical Wiring

Model Number	Description	Shipping Weight	
		Lb.	Kg.
DI-3	Ionization Smoke Detector	1	.45
DI-3IS	Ionization Smoke Detector (Intrinsically Safe)	1	.45
DI-3H	Ionization Smoke Detector (High Altitude)	1	.45
DI-A3	Ionization Smoke Detector (High Air Velocity)	1	.45
DI-A3H	Ionization Smoke Detector	1	.45
DI-B3	Ionization Smoke Detector (Duct Use Only)	1	.45
DI-B3H	Ionization Smoke Detector (High Altitude-Duct Use Only)	1	.45
DB-3S	Low profile mounting base	1	.45
ADB-3	Audible base	1	.45
DB-LK	Series 3 base locking kit	.50	.23
AD-31	Series 3 air duct housing (See Catalog Sheet #6124)	5	2.25
DA-3SR	Duct Relay Module (Conventional)	.50	.23
SA-31	Series 3 self-contained air duct housing (See Catalog Sheet #6124)	7	3.15
RR-3S	Remote Relay (DPDT)	1	.45
RL-30	Remote alarm lamp (Incandescent)	1	.50
RL-40	Remote alarm lamp (Incandescent)	1	.50
GP-7A	Aerosol detector tester	7	3.15
GC-7	Replacement gas container for GP-7A	1	.45
RLI-1	Remote alarm lamp LED	.50	.23
RLI-2	Remote alarm lamp LED	.50	.23
RA-ADB	Finish Trim Ring	.50	.23



Your Portal to the Industrial World

**IndustrialZone**  
P.O. Box 667306  
Houston, Texas 77266  
United States

(713)-395-1508  
Fax: (713) 893-6924  
support@industrialzone.com  
[www.industrialzone.com](http://www.industrialzone.com)

**NOTICE:** The use of other than Fire Safety detectors and bases with Fire Safety control equipment will be considered a misapplication of Fire Safety equipment and as such void all warranties either expressed or implied with regards to loss, damage, liabilities and/or service problems.