

Digi-Pulse™ Flow Monitor

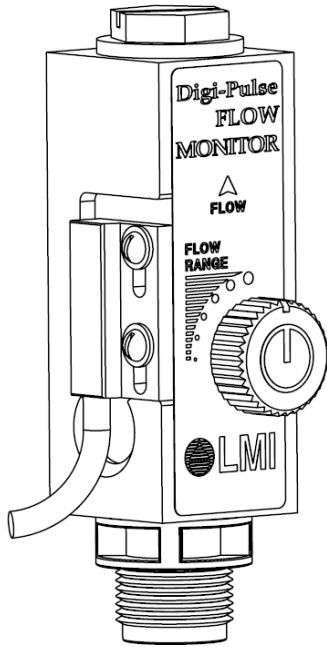

- Corrosion resistant PVDF
- Senses pulsating metering pump flow
- Adjustable, in-line

Pulsating flow of your pump can be monitored and transmitted using the LMI Digi-Pulse™ Flow Monitor. Designed to electrical-ly signal a low flow or no flow condition, you can be assured of your pumping performance; an advantage when working with pulsating or very low flows. A transmitter can be connected to a remote counting or recording device. The FM-259/359/459/859 transmitters are wired to be plugged directly into the receptacles of Series B9/C9 pump housings. Additionally, the FM-879 can be directly plugged into the flow monitor input (4-pin connector) on the Series AD9 pump housing. The Digi-Pulse™ Flow Monitor is adjustable to any desired pulsating flow rate within its range.

SPECIFICATIONS	FM-250	FM-259	FM-350	FM-359	FM-450	FM-459	FM-850	FM-859	FM-879
Cable Length	10 ft (3 m)	20 in (0.5m)	20 in (0.5 m)		FM-450, FM-850: 10 ft (3 m) FM-459, FM-859, FM-879: 20 in (0.5 m)				
Flow Range	0.05 - 5.0 ml/stroke		0.5 - 16.0 ml/stroke		0.05 - 5.0 ml/stroke				
Max LMI Pump Output	7.9 GPH (30.0 l/h)		25 GPH (95 l/h)		7.9 GPH (30.0 l/h)				
Max Pulse (Stroke) Rate	100/minute				240/minute				
Max Pressure	150 psi (10 bar)								
Transmitter	Reed switch (No Flow = N.O. Switch Condition) Polarity Independent Min pulse width 15 msec								
Max Load	100 mA AC or DC, 36 V max								
Body Material	PVDF								
Valve Fitting Material	Carbon Fiber Reinforced PVDF (where supplied)								
Seals & O-Rings	Polyprel® (PTFE copolymer)								

CONFIGURATIONS		
Model No.	For Use With	Liquid End Series
FM-250	3/8" check balls and 4FV	LEGACY
FM-259	Series B9/C9 pumps with 3/8" check balls, 3.5 mm connector	
FM-350	1/2" check balls/tubing (9 x12 mm), PVDF valve housing	
FM-359	1/2" NPT for Series B9/C9 pump, male PVDF valve housing, 3.5 mm connector	
FM-450	Legacy 3FV/4FV (single ball lower valve fitting)	300 and 400 LIQUIRPRO™
FM-459	Legacy 3FV/4FV and Series B9/C9 pump, 3.5 mm connector (single ball lower valve fitting)	600, 800, and 900 FASTPRIME™ or AUTOPRIME™
FM-850	Roytronic 4FV and Series A pump (double ball lower valve fitting)	
FM-859	Roytronic 4FV and Series B9/C9 pump, 3.5 mm connector (double ball lower valve fitting)	
FM-879	Roytronic 4FV and Series AD9 pump, 4 pin connector (double ball lower valve fitting)	

Accessory:

Right Angle Adapter Assembly P/N 49216 is oriented the DIGI-PULSE™ Flow monitor series FM-4xx or FM-8xx vertically for use with AUTOPRIME™ Liquid Ends.

Digi-Pulse™ Flow Monitor Installation

1. With your pump turned off, screw the lower valve fitting of the Digi-Pulse™ Flow Monitor to the discharge side of the pump head.
2. **FM-2xx/FM-4xx/FM-8xx:** Remove the Caplug from the top of the Digi-Pulse™. *Be sure to save the O-Ring seal and spacer to install onto the mating end of the valve housing or 4FV you will be using.* Attach your 4FV or valve housing to the top of the Digi-Pulse™.
- FM-3xx:** Attach tubing/pipe to top of valve housing.
3. Connect the Digi-Pulse™ cable to your counter, computer, or other recording device (polarity is not critical). If cable extension is desired, consult factory. Plug the Digi-Pulse™ cable directly into the receptacle in the Series A9/B9/C9 pump housing. Plug the FM-879 directly into the flow monitor input (4-pin connector) within the Series AD9 metering pump housing.
4. Loosen the locknut of the flow-range knob of the flow monitor and set the knob to the largest dot. Start the pump and adjust it (calibrate, if necessary) for proper output to satisfy your system requirements.
5. With the pump running, gradually turn the adjustment knob of the flow monitor counter-clockwise until the sensor just begins to trigger your electronic device. This will be the most sensitive setting of the Digi-Pulse™, given your pump setting and fluid properties. Every stroke of the pump will output enough volume of solution to cause the Digi-Pulse™ flow monitor to register a pulse. If the flow drops below the initial pump setting, the Digi-Pulse™ will no longer register strokes to your electronics, indicating some type of pump failure or low-level condition.
6. Tighten the adjustment locknut without altering the adjustment position.

Note: After the initial pump and Digi-Pulse™ setup is complete, any adjustment of the stroke length of the pump (output per stroke) will require a readjustment of the Digi-Pulse™ Flow Monitor (repeat steps 4 - 6 above).

To change the flow range setting:

Set screws hold the reed switch transmitter body on the side of the flow monitor. Remove the screw and washer and slide the transmitter up or down to an alternate position and tighten the screw and washer to secure the transmitter. The Digi-Pulse™ Flow Monitor comes factory set at the low setting which should accommodate most applications. However, adjustment may be necessary for a particular application if the sensor does not trigger in the low setting.

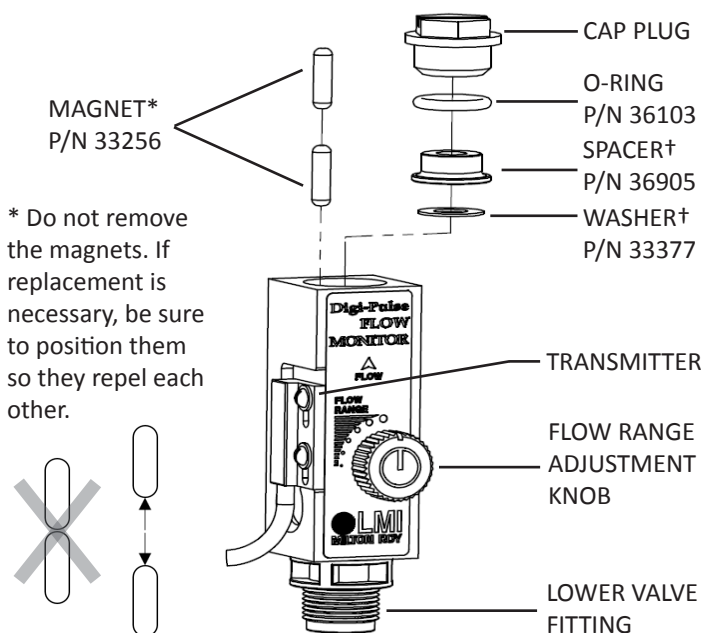

† Washer only in FM-2xx/3xx models. Spacer only in FM-4xx/8xx models