

FLOMORE

Different By Design

5200 Series Injector



5200 Series Injector

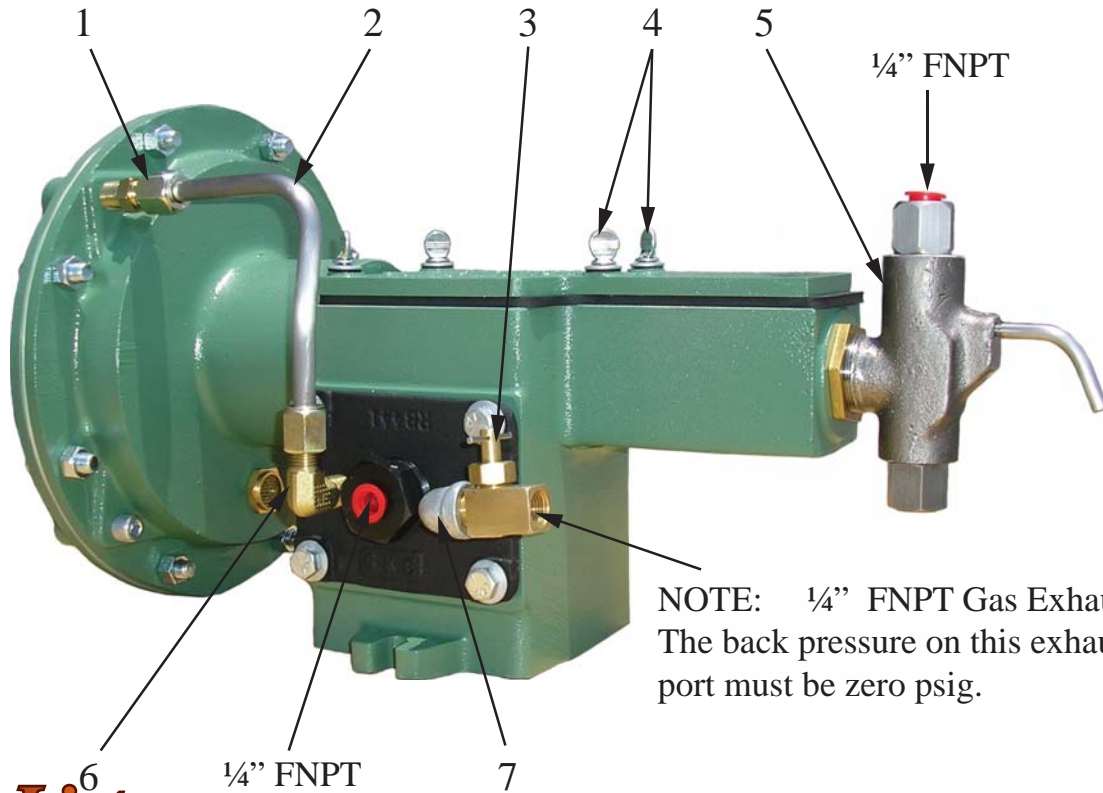

NOTE: 1/4" FNPT Gas Exhaust
The back pressure on this exhaust
port must be zero psig.

Parts List

Item #	Part #	# Reqd.	Description	Material
1	A-4015	1	Male Connector and Compression Nut Assembly	Cadmium Plated Carbon Steel
2	B-1193	1	Pilot Valve Line Assembly	303 Stainless Steel Tubing with Cadmium Plated Fittings
3	A-2489	1	Gas Exhaust Valve	Nickle Plated Brass
4	A-0136	4	Wing Screws	Cadmium Plated Steel
5	See Page 8	1	Injector Head	See Page 8
6	A-4016	1	Elbow Connector and Compression Nut Assembly	Cadmium Plated Carbon Steel
7	A-0075	1	Street Ell	Cadmium Plated Carbon Steel
8	A-0664	1	5 Gallon Tank	304 Stainless Steel
	A-1539		10 Gallon Tank	
9	A-3118	1	Connector	Polypropylene
10	A-3116	1	Elbow Connector and Compression Nut Assembly	Polypropylene
11	A-0950	1	Base	Steel
12	A-3123	1	3/8" x 22" Suction Line	Polypropylene
13	A-0167	4	Cut Washer	Steel
14	A-0425	2	Lock Washer	Steel
15	A-0144	1	Hex Nut	Steel
16	A-0142	1	Hex Head Cap Screw	Cadmium Plated Steel
17	F-0871	1	5 Gallon Tank Gauge	♦
	A-1285		10 Gallon Tank Gauge	

*Parts not pictured

Installation and Operating Instructions

First check for the following items shipped loose, not installed on the pump: (1) ¼” male x female line check, (1) A-0315 packing gland wrench, and (1) A-1497 priming valve.

1. Blow or clean dirt or other objects from gas supply line, if pressure exceeds 35 PSI reduce with regulator at pump. Do not connect to the small ¼” valve (A-2489) this is the gas exhaust.
2. Install the furnished line check at the point of injection noting the flow arrow on the valve. Connect the discharge line into the ¼” FNPT in both the line check and the top discharge bushing (A-1496) of the head assembly. (Make sure this line is clear of debris.)
3. If pumping from a liquid source other than our 5 gallon reservoir (A-0664) we recommend the use of our liquid level drum gauge (F-0871). This will allow you to conserve costly chemicals by accurately setting the pumping rate desired. It further gives a visual check that the pump is functioning properly. Connect the suction line to the drum gauge and to the bottom suction bushing. It is important this line be clear of any foreign material.
4. Install the “L” shaped priming valve (A-1497) into the small threaded hole in the injection head, leave it partially open.
5. Add a lightweight SAE 5 oil to that portion of the reservoir that contains the spring (A-1820) you can see after removing the top cover (B-0548) and gasket (A-1546). Pour oil on top of the thrust rod and fill to the bottom of this rod.
6. Open the main gas shut-off valve and the small gas exhaust (A-2489). The pump will start automatically. Keep hands and fingers away from the moving parts.
7. Check priming valve (A-1497) opening for air bubbles in liquid being pumped. As soon as bubbles stop, close priming valve and adjust pump for desired SPM and pumping rate. A quick check of packing gland nut (A-4104) to see if there is packing leakage, if so tighten slightly with wrench furnished. **Do not overtighten** because it may stall pump and/or cause excessive packing wear.
8. Replace cover and gasket with thumb screws.

Applications

- The introduction of de-emulsifiers, solvents, corrosion inhibitors, de-scaling agents and oxygen scavengers.
- Water treatment
- Injection of methanol in gas pipelines
- Injection of surfactant (soap) into low pressure gas wells with high water content.

Accessories & Optionals

- Teflon or Viton Packing
- Slow Speed Controller
- Microswitch Valve Controller
- CxC Non-packing Head Assembly

Sour Gas Trim

5200 Series Injectors are furnished with sour gas trim as standard.

5200 Series Injector

Cross Section

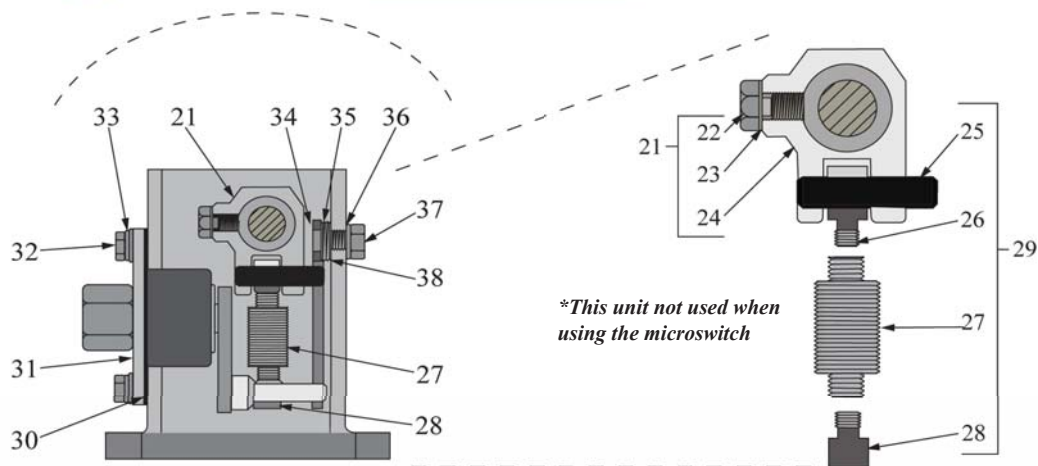
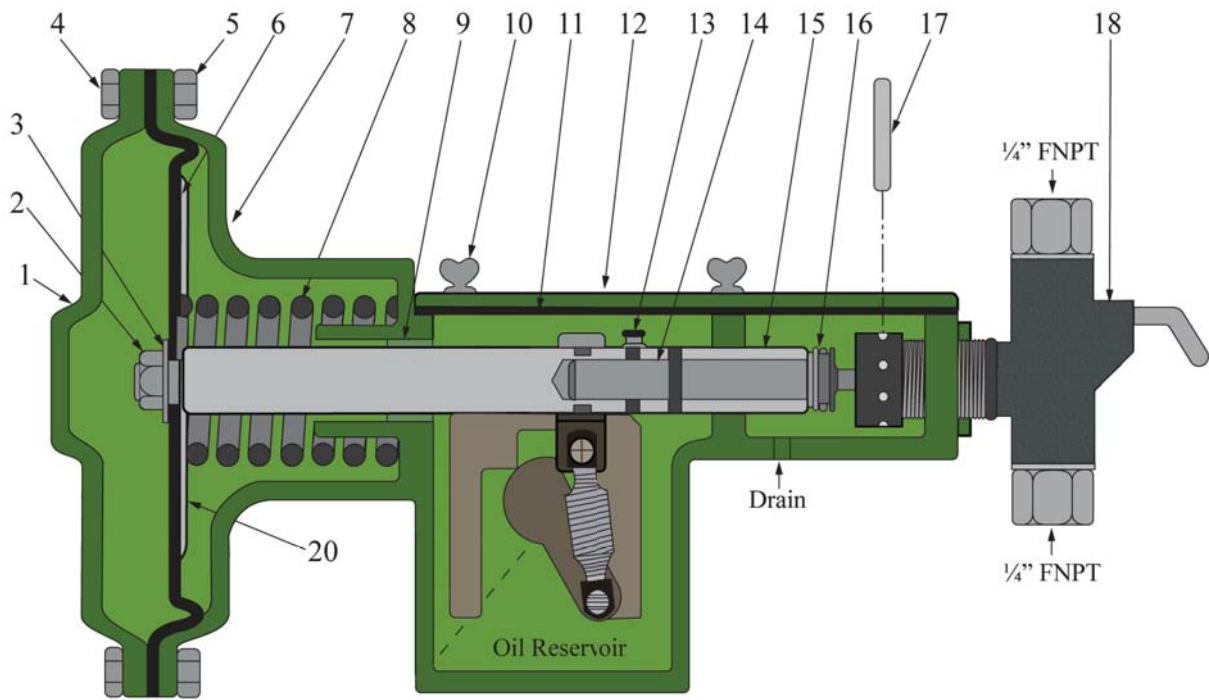

5200 Series Injector

Parts List

Item #	Part #	# Req'd.	Description	Material
1	C-0252	1	Diaphragm Cover	Aluminum
2	A-3320	1	Locknut	Cadmium Plated Steel
3	A-3321	1	Washer	Cadmium Plated Heavy Steel
4	A-0139	8	Hex Head Cap Screw	Steel
5	A-2207	8	Hex Nut	Steel
6	C-0290	1	Molded Diaphragm	Buna-N, Nylon
7	D-0251	1	Housing	Aluminum
8	A-1821	1	Return Spring	Cadmium Plated Carbon Steel
9	B-0001	1	Bearing	Bronze
10	A-0136	4	Wing Screws	Cadmium Plated Steel
11	A-1546	1	Gasket	Buna-N
12	B-0548	1	Cover	Aluminum
13	A-1828	1	Adjusting Pin	Steel
14	B-0447SS	1	Rod Adapter	303 Stainless Steel
15	B-0444SS	1	Thrust Rod	303 Stainless Steel
16	A-0290	1	Pin	Steel
17	A-0315	1	Gland Wrench	Steel
18	See Page 8	1	Injector Head	See Page 8
19	A-1835	1	Air Vent	Brass
20	B-0438	1	Diaphragm Plate	Steel
21	A-1832	1	Stirrup Sub-Assembly	Aluminum and Steel
22	A-1829	1	Hex Head Screw	Steel
23	A-3406	1	Internal Tooth Lockwasher	Cadmium Plated Carbon Steel
24	B-0471	1	Trip Stirrup	Aluminum
25	A-2355	1	Roll Pin	Steel
26	A-1838	1	Spring Adapter (top)	Steel
27	A-1820	1	Flipper Spring	Steel
28	A-1838	1	Spring Adapter (bottom)	Steel
29	A-1831	1	Stirrup Assembly	◆
30	A-0058	1	Pilot Valve Gasket	Fiber
31	C-0446	1	Pilot Valve	◆
32	A-0141	4	Hex Head Machine Screw	Cadmium Plated Carbon Steel
33	A-0425	4	Lockwasher	Cadmium Plated Steel
34	A-1827	1	Bumper Plate Screw	Steel
35	A-1823	1	Bumper Plate	Steel
36	A-0459	1	Light Lockwasher	Cadmium Plated Steel
37	A-3323	1	Hex Nut	Cadmium Plated Semifinish Steel
38	A-0746	5	Washer	Steel

* Recommended Spare Parts

**Parts packaged separately

5200 Series Replaceable Seat

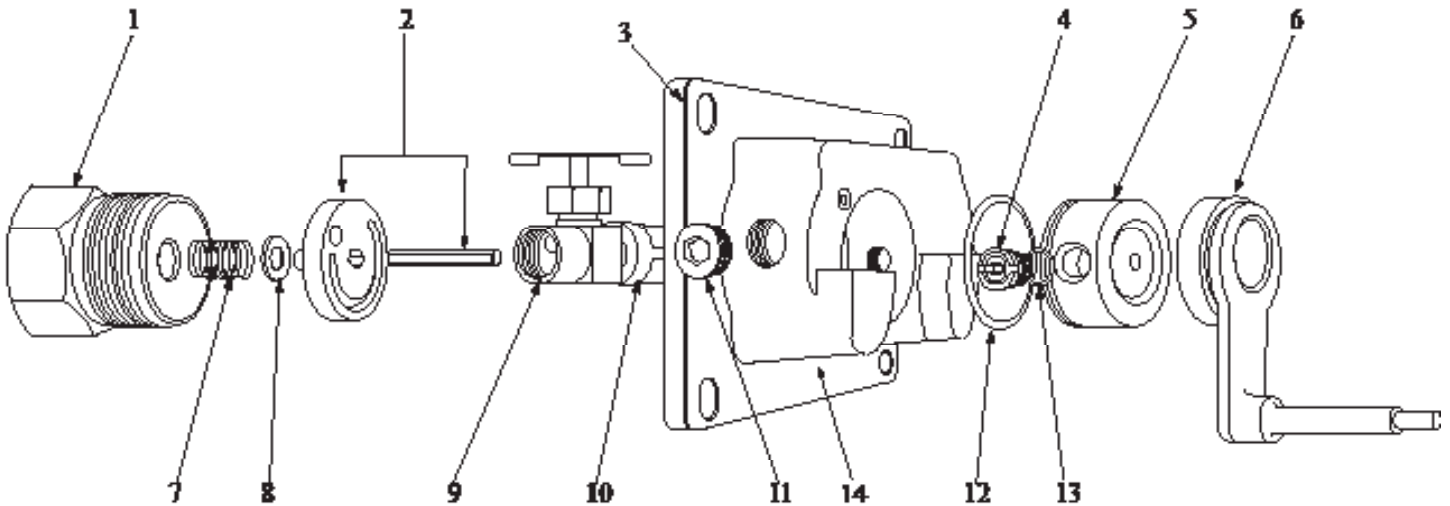

NOTE: Using small amount of grease, lubricate Items #12 and #13, o'rings, before and after installation on Item #5. This will keep o'rings in place and facilitate the pressing of the valve seat into position.

Parts List

<i>Item #</i>	<i>Part #</i>	<i># Reqd.</i>	<i>Description</i>	<i>Material</i>
1	C-0495	1	Disc Retainer	Steel
2	C-4147	1	Valve Disc and Pin	Stainless Steel
3	C-0441	1	Pilot Valve Body	Ductile Iron
*4	C-0463	2	Seat Seal Screw	Steel
5	C-0451	1	Valve Seat	Steel
6	B-0440	1	Flipper Arm Assembly	Steel
7	A-0077	1	Spring	Steel
8	A-0579	1	Washer	Stainless Steel
9	A-2489	1	Valve	Brass
10	A-0075	1	Street Elbow	Steel
11	C-3386	1	Flush Seal Plugs	Steel
12	C-0485	1	Seat Seal O'Ring	Buna-N
*13	C-0474	2	Seat Seal Screw O'Ring	Buna-N
14	A-0058	1	Gasket	Fiber

* Recommended Spare Parts

**Items make up a C-0500 Pilot Valve Seat and Disc Assembly

5200 Series Components

A-0675 & A-0676 Line Check

Parts List

Item #	Part #	# Req'd.	Description	Material
1	A-0678	1	Inlet Body	Brass
	A-1297	1	Inlet Body	303 Stainless Steel
2	A-1574	1	Washer	304 Stainless Steel
3	A-0479	1	O'Ring	Buna-N
	A-2580	1	O'Ring	Viton
4	A-0054	1	3/8" Ball	316 Stainless Steel
5	A-0391	1	Spring	Steel
6	A-0679	1	Outlet Body	Brass
	A-1296	1	Outlet Body	303 Stainless Steel

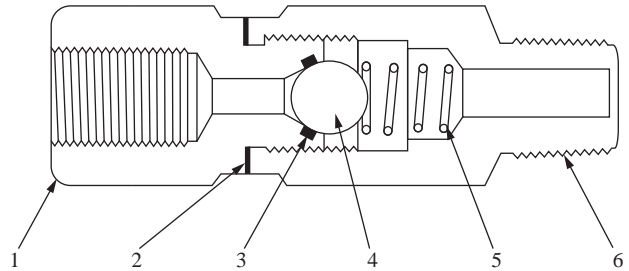

* Recommended Spare Parts

**A-0675 Only

***A-0676 Only

F-0871 Model 2000 Tank Gauge

Parts List

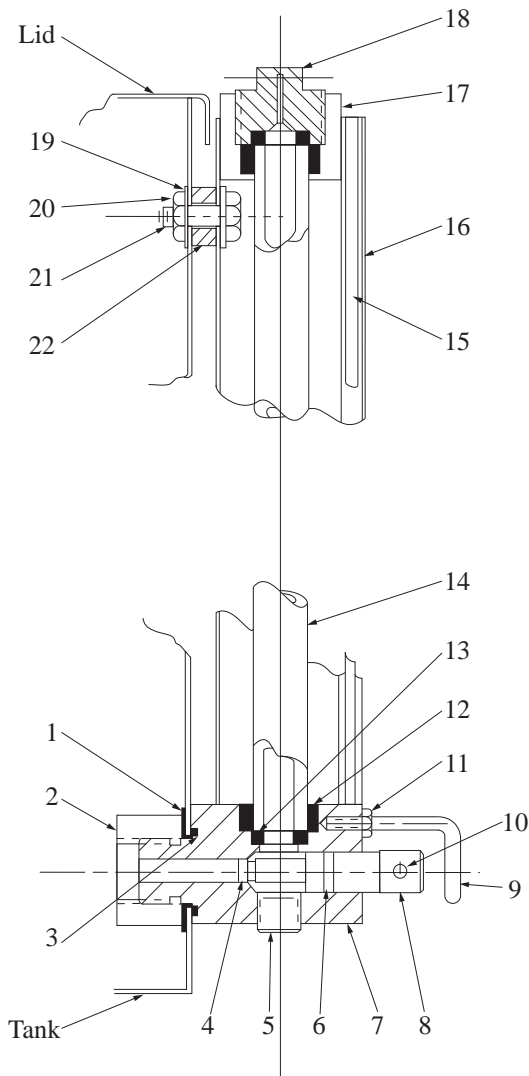

Item #	Part #	# Req'd.	Description	Material
1	A-0306	1	Washer	Teflon
2	F-0871.01	1	3/4-16" Nut	Stainless Steel
3	F-0871.03	1	2-019 O'Ring	Viton
4	F-0871.04	1	2-006 O'Ring	Viton
5	A-0138	2	1/4" NPT Pipe Plug	Steel
6	F-0871.06	1	2-011 O'Ring	Viton
7	F-0871.07	1	Valve Body	Stainless Steel
8	F-0871.08	1	Valve Stem	Stainless Steel
9	F-0871.11	1	Valve Stop	Stainless Steel
10	F-0871.09	1	1/8" x 2" Roll Pin	Stainless Steel
11	F-0871.10	1	Valve Stop Nut	Stainless Steel
12	15470	2	Tube Gasket	Buna-N
13	D-0013	2	Tube End Seal	Viton
14	A-3102	1	Glass Tube	Glass
15	F-0871.15	1	Scale	Acrylic
16	F-0871.16	1	Housing	Stainless Steel
17	F-0871.17	1	Top Block	Aluminum
18	F-0871.18	1	Vent Plug	Stainless Steel
19	A-4092	2	Stat-O-Seal	Steel
20	F-0871.20	1	1/4-20" Nut	Stainless Steel
21	F-0871.21	1	1/4-20" x 3/4" Bolt	Stainless Steel
22	A-0987	1	Spacer	Stainless Steel

Injector Heads

Alternate Construction

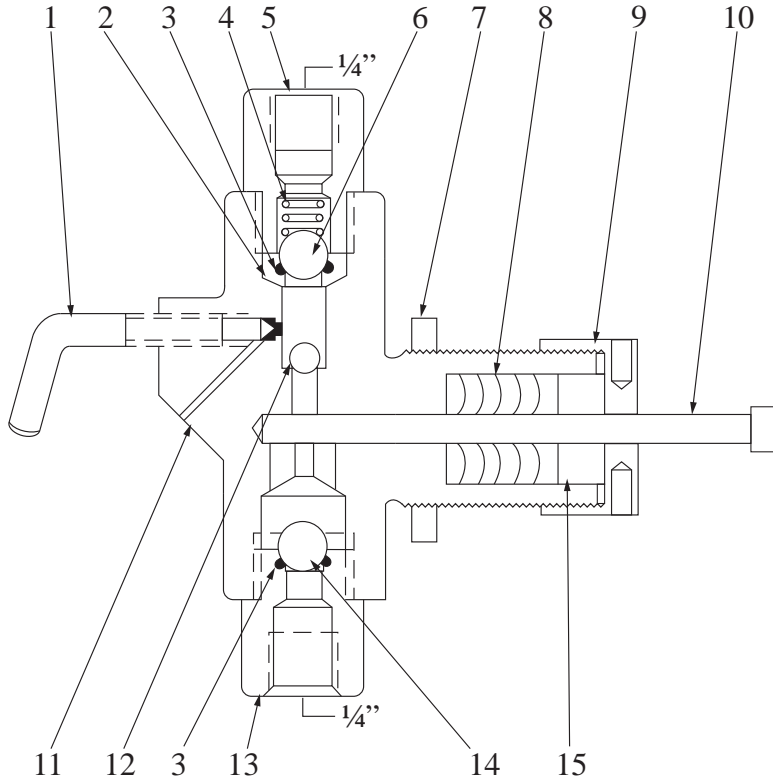

Item #	Part #	Description	Material	
2	A-0806	Top Seat Assembly (Metal-to-Metal)	303 Stainless Steel	
2	B-0843	Top Seat with Viton O'Ring	303 Stainless Steel	
3	A-2580	O'Ring	Viton	
8	◆	3/16" Plunger Packing	Hard	
	A-3967		Viton	
	A-3966		Teflon	
	A-2295	1/4" Plunger Packing	Hard	
			A-4102	Viton
			A-1642	Teflon
	A-1875	3/8" Plunger Packing	Hard	
			A-4101	Viton
			A-1234	Teflon
	A-1874	1/2" Plunger Packing	Hard	
A-4103			Viton	
A-1012			Teflon	
* 13	A-0771	Bottom Seat Assembly (Metal-to-Metal)	316 Stainless Steel	
13	B-0844	Suction Bushing with Viton O'Ring	303 Stainless Steel	
* 14	A-0053	1/2" Suction Ball	316 Stainless Steel	

*Recommended Spare Parts

**Items must be used together

Plunger Packing Chart

Material	Maximum Discharge Pressure (PSIG)			
	3/16"	1/4"	3/8"	1/2"
Buna-N		1500	1500	1500
Viton		3500	3500	3500
Hard		6000	6000	3500
Teflon		1500	1500	1500

Parts List

Item #	Part #				# Reqd.	Description	Material
	3/16"	1/4"	3/8"	1/2"			
◆	◆	B-0166	B-0203	B-0496	1	Head Assembly	Ductile Iron with Stainless Steel Trim
	B-1299	B-0755	B-0756	B-0732			All Stainless Steel
1	A-4027	A-1497			1	Priming Valve	303 Stainless Steel
* 2	B-0737				1	Top Seat Assembly- Buna	303 Stainless Steel
* 3	A-0479				1	Suction & Discharge O'Ring	Buna-N
4	A-0077				1	Ball Check Spring	316 Stainless Steel
5	A-1496				1	Top Bushing	303 Stainless Steel
6	A-0054				1	3/8" Large Top Ball	316 Stainless Steel
7	A-0225				1	Locknut	Brass
* 8	A-3969	A-1461	A-1456	A-0959	1	Plunger Packing	Buna-N
9	A-4104				1	Plunger Packing Gland Nut	303 Stainless Steel
10	A-4747	A-1312	A-1745	A-1876	1	Plunger	17-4 pH Stainless Steel
11	◆	C-0275	C-0276	C-0272	1	Body	Ductile Iron
	C-2040	C-0291	C-0425	C-0349			Stainless Steel
	◆	A-0126			1	1/4" Small Top Ball	316 Stainless Steel
* 13	B-1216	B-0736			1	Bottom Seat Assembly-Buna	303 Stainless Steel
* 14	A-0054				1	3/8" Suction Ball	316 Stainless Steel
15	A-4332	A-1463	A-0957	A-1219	1	Plunger Packing Gland	303 Stainless Steel
16	A-0126	◆			1	1/4" Ball	316 Stainless Steel
17	A-4394	◆			1	Suction Bushing Sealing Washer	304 Stainless Steel

*Recommended Spare Parts

** Alternate construction available see chart above

Dimensions and Performance Data

Dimensions

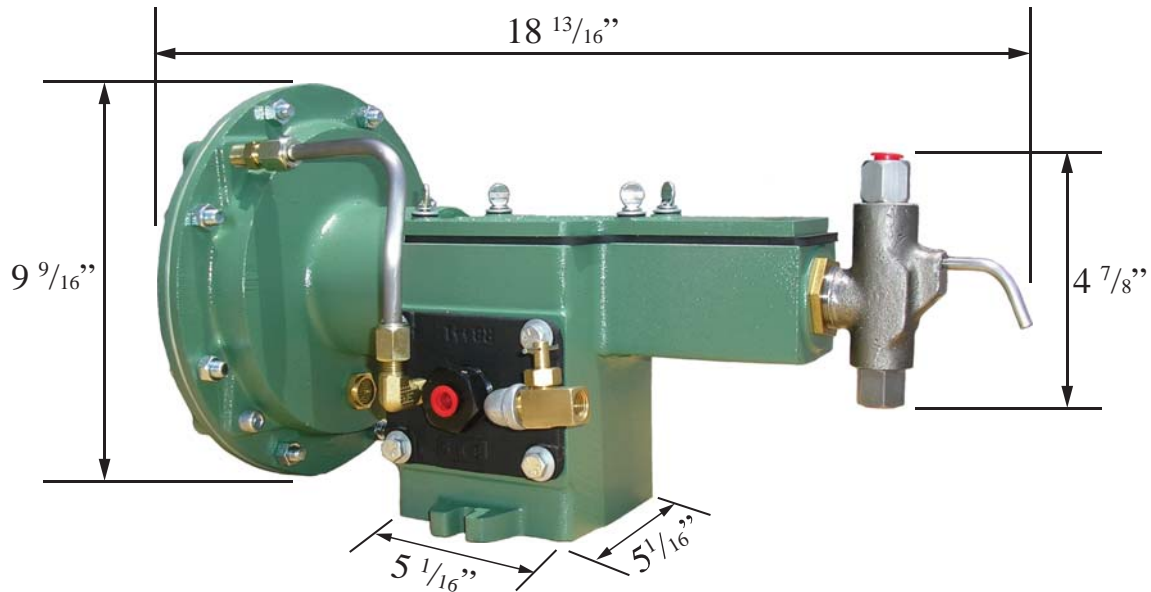

5200 Series Gallons Per Stroke

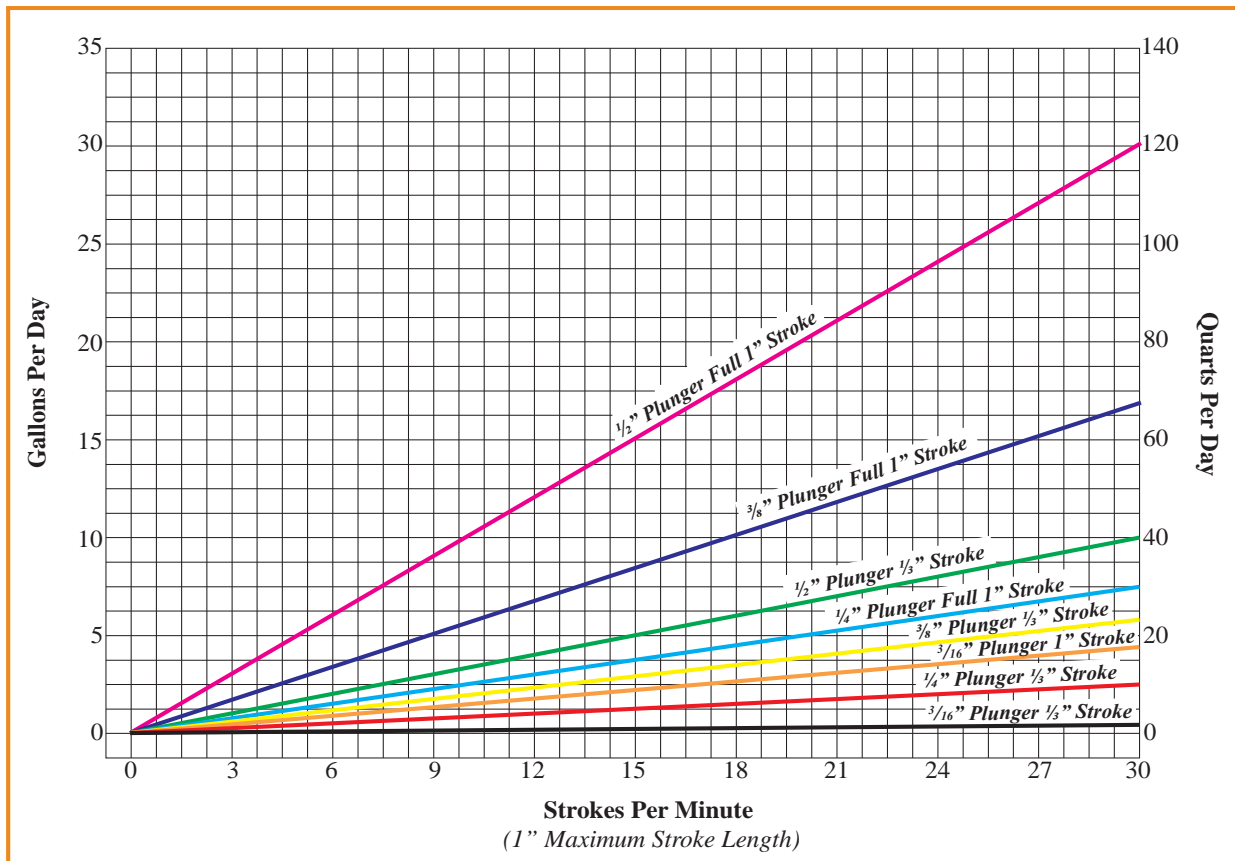

Performance Data

Gas Consumption Chart

Stroke Length	Piston Size	* Cubic Feet of gas required per gallon per day							Injection Pressure (PSI)			
		100	200	500	1000	1500	2000	3000	3500	4000	5000	6000
1/3 Stroke	3/16"	1371	1374	1386	1407	1428	1590	1635	1665	1680	1725	1776
	1/4"	732	735	744	810	864	924	1020	1065	1107	1215	1491
	3/8"	360	378	444	492	531	555	729	834	942	1065	1122
	1/2"	159	162	171	186	213	228	252	285	♦	♦	♦
Full Stroke	3/16"	457	458	462	469	476	530	545	555	560	575	589
	1/4"	244	245	248	270	288	308	340	355	369	405	497
	3/8"	120	126	148	164	177	185	243	278	314	355	374
	1/2"	53	54	57	62	71	76	84	95	♦	♦	♦

Maximum Recommended Speed Above 1500 PSI Injection Pressure

Plunger Size	Strokes Per Minute
3/16"	28
1/4"	26
3/8"	14
1/2"	14

Power End to Fluid End Ratio

Plunger Size	Operating Ratio Fluid/Gas
3/16"	1200/1
1/4"	750/1
3/8"	300/1
1/2"	180/1

Pressure / Volume Chart

Series	Plunger Size	Maximum Discharge Pressure (PSI)	For Operation Off Air or Gas Pressure to 35 PSI (constant)			
			Power Unit *		Chemical Injector **	
			Model #	Max. Vol. (GPD)	Model #	Max. Vol. (GPD)
5200 Standard	3/16"	1500	52-04	4.2	52-04T	4.2
	1/4"	1500	52-01	7.5	52-01T	7.5
	3/8"	1500	52-03	16.8	52-03T	16.8
	1/2"	1500	52-05	32	52-05T	32
5210 High Pressure	3/16"	6000	52-14	3.65	52-14T	3.65
	1/4"	6000	52-11	6.5	52-11T	6.5
	3/8"	6000	52-13	7.9	52-13T	7.9
	1/2"	3500	52-15	14	52-15T	14

* Basic pump no tank, base, regulator or gauge (Shipping weight: 22lbs)

** Furnished with 5 gallon stainless steel tank mounted on heavy galvanized steel base with level gauge and suction line, no regulator or gauge (Shipping weight: 32lbs)

Maintenance and Troubleshooting

Oil Thrust Rod

Put oil on top of thrust rod occasionally, then replace cover.

Packing Leakage

Check for packing leakage, tighten or replace as needed, overtightening will shorten life and may score the plunger which will need to be replaced.

Use Correct O'Rings

Any Flomore pump used to pump methanol or alcohol to prevent freezing must be equipped with buna-n o'rings. Pumps used to pump chemicals should be equipped with viton o'rings, these are located in the top seat (B-0737) and suction bushing (B-0736).

Pump Stopped Running and Gas is Escaping

Should pump stop running but you can hear gas escaping from vent (A-1835) remove diaphragm cover (C-0252) and inspect diaphragm for hole or tear, replace as needed. At this time, visually inspect larger turning spring (A-1821) for breakage. When installing a new diaphragm, put a sealant line Permatex "Form a Gasket" around the center hole on both sides of the diaphragm. This will prevent gas leak in that area. Reinstall diaphragm making sure the small hole on outer edge of diaphragm and diaphragm cover line up with pilot valve gas line that brings gas to the diaphragm chamber.

No Gas is Venting from Gas Exhaust Valve

If you do not hear gas venting, check gas supply and pressure (35PSI max), overpressure and underpressure can cause pump to stall.

Pump Stalls in Forward Discharge Position

Turn off gas supply, check flipper arm spring (A-1820), if it is intact then loosen packing gland nut, packing may be too tight. If pump still does not make return stroke suspect broken return spring (A-1821). (See Pump Stopped Running and Gas is Escaping)

Pump Still Stalled

Check oil reservoir for gas bubbles, a small amount of leakage can be tolerated, however larger amounts of leakage can cause pump to stall. Check supply pressure (35 PSI max), if pressure is within limits the pilot valve (C-0442) may have to be replaced. However, with our replaceable seat and disc assembly (Page 6) only the disk (C-4147) or seat assembly (C-0500) may have to be replaced.

Pump is Running but Not Pumping

There could be air in the injection head, open priming valve (A-1497) until air bubbles in fluid subside. If still not pumping, it is probably the o'ring in the suction bushing is not the correct material (See Use Correct O'Rings).

Flipper Arm Spring (A-1820) is Broken

Drain oil into suitable container and save to replace in reservoir. Remove (C-0446) pilot valve assembly, then remove broken spring from flipper arm (B-0440). Loosen (A-1829) hex screw on the (A-1832) stirrup assembly, rotate assembly, remove (A-2355) rollpin, install new (A-1820) spring slide pilot valve assembly partially in and reattach (A-1838) spring adapter, retighten (A-1829) making sure it is in the groove on the thrust rod, rebolt (C-0446), replace oil and restart pump (See Pump Stalls in Forward Discharge Position and Pump Still Stalled).

FLOMORE

Richart Distributors, Inc.

Corporate Office

3415 South I-35 Service Road
Oklahoma City, OK 73129
1-866-843-5654
Fax: (405) 619-3007
Richart@flomore.com

Weatherford Branch

2041 FM 920
Weatherford, TX 76088
(817) 599-9630
Fax: (817) 599-9167
Mike.Mayes@flomore.com

Dickinson Branch

533 East Villard Suite B
Dickinson, ND 58601
(701) 483-8267
Fax: (701) 483-8268
RichartND@flomore.com

Kilgore Branch

820 South Commerce Street
Kilgore, TX 75662
(903) 984-3070
Fax: (903) 984-7901
Tammy.Hunt@flomore.com

Louisiana Branch

Cardon Sales Company, LLC

213 Cummings Road
Broussard, LA 70518
(337) 839-1704
Fax: (337) 839-1706
bcardon@cardonsales.com

Odessa Branch

Patterson Equipment Sales, Inc

1610 S. Regal Avenue
Odessa, TX 79763
(432) 332-3345
Fax: (432) 332-3348
chad@pattersonequipsalesinc.com



IndustrialZone
P.O. Box 667306
Houston, Texas 77266
United States

(713)-395-1508
Fax: (713) 893-6924
support@industrialzone.com
www.industrialzone.com