

a xylem brand

SELF-PRIMING PUMPS Electro-Magnetic Clutch Units FEATURES

Body: Bronze
Impeller: Jabsco Nitrile Compound
Shaft: Brass
Ports: 2" NPT
Seal: Carbon-Ceramic Face Type
Bearings: Sealed Ball Bearings
Shipping Weight: 29 lb (13,2 kg)

STANDARD MODELS

Model	Voltage	Belt(s)
18330-0000	12 Vdc	2-A
18330-0040	12 Vdc	1-B
18330-0001	24 Vdc	2-A
18330-0041	24 Vdc	1-B

APPLICATIONS

MARINE: Engine cooling, Pumping bilges, Washdowns, Circulating water in bait tanks, Utility dockside pump.

INDUSTRIAL: Circulating and transferring, Velocity-mixing, Return spill, Sump drainage, Chemicals, Pharmaceuticals, Soap, Liquors, Ink, Dyes, Alcohol, Tanning Liquors, Glycerine, Brine, etc.

FARMING: Pumping water for stock, Pumping water from shallow wells and cisterns.

PUBLIC UTILITIES AND MUNICIPALITIES: Under the hood mounting on service trucks for dewatering and draining meter boxes, manholes, excavations, and truck installation under hood for emergency pumping.

INSTALLATION

Pump may be mounted in any position. Intake and discharge ports are determined by the direction of shaft rotation (refer to dimensional drawing). Before installing, energize clutch and turn pump shaft in direction of shaft rotation. Drive pump with two "A" size belts. Avoid dry-running by using Vacuum Switch Model 4732-0000 for automatic shut-off.

NOTE: MODEL 18330-SERIES IS INTERCHANGEABLE WITH EARLIER PUMP MODEL 10680-SERIES: BASE MOUNTING DIMENSIONS, HEIGHT ABOVE BASE TO SHAFT, AND HEIGHT ABOVE BASE TO PORT CENTER-LINE ARE THE SAME.



Model 18330-Series

WIRING

Connect wires as shown for manual on-off operation. Install proper size fuse (see Electrical Specification Chart) in positive lead ahead of switch and as close to power source as possible. For remote control or automatic shutoff operation, see data sheet on Model 4732-0000 Vacuum Switch Kit (Form 43000-0024). For complete wiring instructions see diagram on page 2.

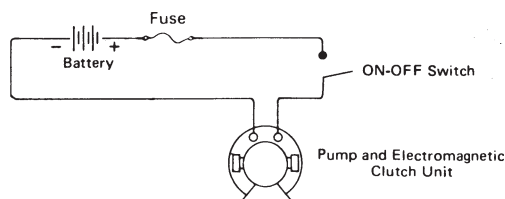

CLUTCH ELECTRICAL SPECIFICATIONS

VOLTAGE	AMP DRAW	FUSE SIZE
12	4	7
24	2	4

OPERATION

Pump will self-prime at low or high speeds. Make sure that all connections are airtight. 12 Volt models are equipped with mechanical clutch engagement screws in case of electrical failure. To mechanically engage clutch, loosen locking nuts, tighten allen head screws and retighten locking nuts. Reverse procedure to disengage clutch. If the mechanical engagement feature is not desired, the screws may be removed. DO NOT RUN PUMP DRY FOR MORE THAN 30 SECONDS. LACK OF WATER FLOW MAY DAMAGE IMPELLER. To drain pump, loosen end cover screws. See Head Capacity Table for head pressures and flow. To avoid costly shutdowns, keep a Jabsco Service Kit on hand.



WARNING Injury hazard. Exposed pulleys and belts can cause injury. Install shield around pulleys and belts. Stay clear while machinery is operating.

EXPLODED VIEW

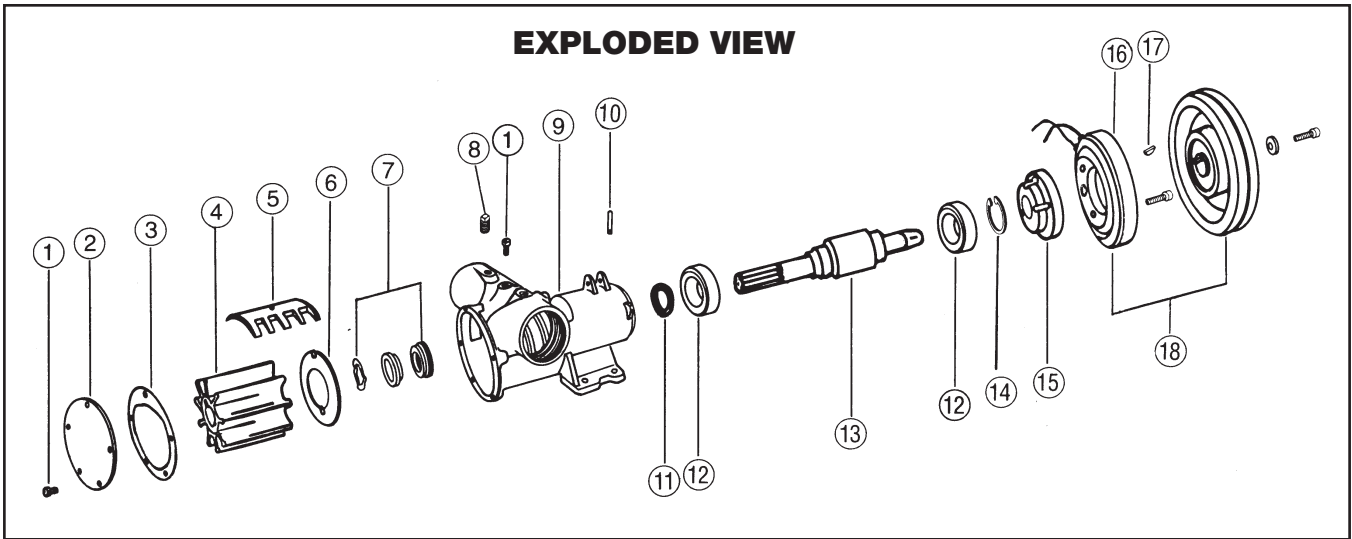

PARTS LIST

KEY	DESCRIPTION	PART #	QTY.
1	Screw (End Cover and Cam)	91005-0040	6
2	End Cover	12062-0000	1
3	* Gasket	816-0000	1
4	* Impeller, Nitrile	6760-0003	1
	* Impeller, Neoprene	17936-0001	1
5	Cam	6988-0000	1
6	Wearplate	2574-0000	1
7	* Seal Assembly (Shaft)	6408-0000	1
8	Pipe Plug	92650-0070	2
9	Body	18313-0000	1
10	Roll Pin	93100-0160	2
11	Bearing Seal	92701-0180	1
12	Ball Bearing	92600-0260	2
13	Shaft	10677-0010	1
14	Retaining Ring	18725-0000	1

KEY	DESCRIPTION	PART #	QTY.
15	Clutch Adaptor	11876-0000	1
16	Field Coil	11876-0000	1
	12 Vdc	98022-0500	
	24 Vdc	98022-2155	
	32 Vdc	98022-0510	
17	Drive Key	91401-0100	1
18	Clutch Assembly		
	12 Vdc - 2-A Grooves	92300-0030	
	12 Vdc - 1-B Groove	18735-0493	
	24 Vdc - 2-A Grooves	92300-0061	
	24 Vdc - 1-B Groove	18753-0494	
	Service Kit, Neoprene	90254-0001	
	Service Kit, Nitrile	90254-0003	

* Parts contained in Service Kit.

NOTES: 1. ALL REPLACEMENT PARTS, (EXCEPT BODY/BEARING HOUSING ASSEMBLY), ARE INTERCHANGEABLE WITH EARLIER PUMP MODEL 10680-SERIES

2. THE STANDARD IMPELLER (6760-0003) IS A 9 BLADE NITRILE (OIL RESISTANT) IMPELLER. FOR NON-CONTAMINATED WATER APPLICATIONS, A MULTIBLADE NEOPRENE IMPELLER (NO. 17936-0001) MAY BE SUBSTITUTED.

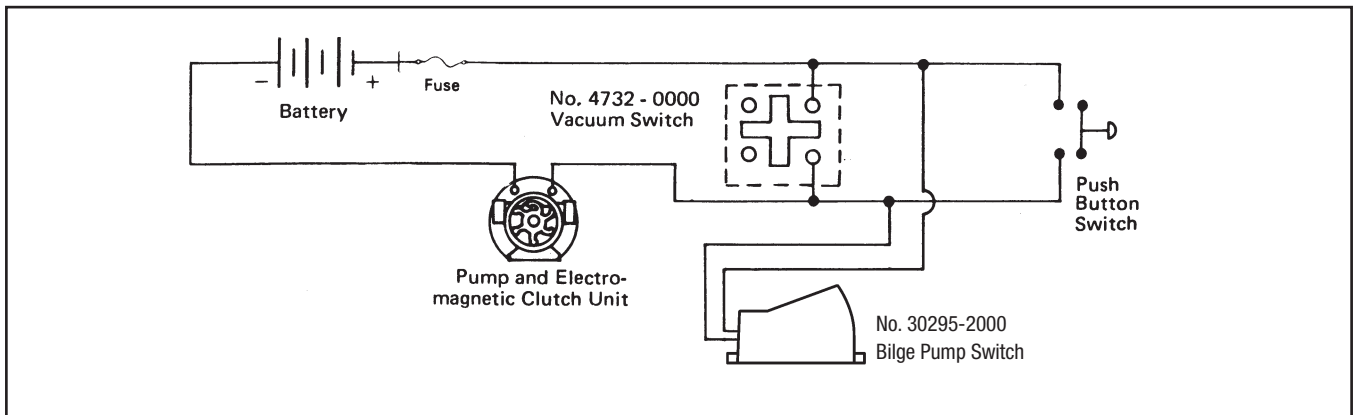

REMOTE CONTROL (When Engine Is Running): Install a pushbutton switch at one or more locations. Depress pushbutton for 2 seconds. If there is water in bilge, pump will operate until dry at which time vacuum switch will stop pump. If no water is in bilge, pump will stop when pushbutton is released.

AUTOMATIC BILGE PUMP (When Engine Is Running): Install No.30295-2000 Automatic Bilge Pump Switch where it will energize clutch at maximum high water level in bilge. When water raises switch float, pump will start. Vacuum switch will maintain closed circuit until bilge is pumped dry. Pump will automatically stop, preventing impeller damage.

SERVICE INSTRUCTIONS

IMPELLER REPLACEMENT: Remove end cover and O-ring. Pull impeller out by grasping hub with pliers or impeller puller. With a rotary motion in the direction the pump will be turning, push impeller into the impeller bore. A light coating of grease in the impeller bore will protect impeller during initial dry start up. Install gasket and O-ring.

SHAFT SEAL REPLACEMENT: Remove end cover, O-ring, and impeller as outlined above. Loosen cam screws several times. Give cam screw a couple of sharp raps with the handle of the screwdriver to loosen the cam from the impeller bore. Remove the cam screws and cam (clean sealant from cam and impeller bore). Remove wearplate with hooked wire. Remove snap ring,

Using a hooked wire, and taking care not to scratch shaft or seal seat bore, remove all components of seal assembly. Inspect shaft and seal seat bore to be sure sealing surfaces are free of nicks or scratches. Clean shaft surface behind splines to insure proper seal on shaft. Apply light film of grease on shaft surface behind spline area. Thoroughly clean seal faces (carbon and ceramic) of all grease, oil or particles - this will insure that seal faces will turn freely on startup. Place ceramic seat assembly in body with boot first. Use care not to damage ceramic surface. Be sure ceramic and boot are bottomed squarely in body bore. Slide carbon ring assembly, with carbon facing ceramic, over the shaft and firmly up against the ceramic seat. Install/snap ring/replace wearplate, aligning notch with dowel pin in body. Apply a thin coat of sealant to top of cam and threads on cam to remove from shaft taper. Remove three bolts and washers holding field coil to adaptor. Remove and replace field coil, tightening the three bolts securely. With key drive in place in shaft, replace pulley assembly. Secure to shaft with center bolt and washer (again, it may be necessary to hold the impeller from turning to tighten center bolt). Replace drive belts. Do not overtighten belts. A deflection of 1/2" midway

FIELD COIL REPLACEMENT: Remove drive belts from pulley. Disconnect wiring. Remove center bolt and washer (it may be necessary to remove end cover to hold impeller from turning while removing center bolt). Tap pulley with soft mallet between pulleys is generally considered normal. Reconnect wiring.

MAJOR REPAIR: Remove pump from installation.

DISASSEMBLY: Remove and cover, gasket, impeller, cam and seal assembly as outlined in 'shaft seal replacement'. Remove clutch pulley and field coil as outlined in 'field coil replacement'. Use a punch to drive roll pins (key 10) in towards shaft, approximately 3/8" (10 mm). Remove clutch adaptor from body punch roll pins out of adaptor. Press on impeller end of shaft to remove shaft and bearing assembly from body bearing bore. Use screwdriver to pry inner bearing seat from body. Take care not to scratch or damage body bore. If ball bearings are worn or any slight roughness is felt when the bearing is turned, replace both bearings. Support inner race of bearing and press on impeller end of shaft to remove inner bearing. Replace all worn or damaged parts.

ASSEMBLY: Support inner race of ball bearing. Insert impeller drive end of well oiled shaft to seat inner bearing firmly against shaft shoulder. Reverse shaft and insert tapered end of shaft through bearing supported on inner race. Press on impeller end of shaft to seat second bearing firmly against shaft shoulder. Wipe shaft free of oil. Lightly grease inner bearing seal and press into body bearing bore seating firmly against shoulder bearing seal bore with lip facing towards impeller bore. Support impeller end of body, insert impeller end of shaft through bearing seal and press on outer race of outer bearing to position shaft and bearing assembly into bearing bore, firmly against shoulder. Install clutch adaptor into bearing bore. If resurging adaptor previously disassembled from pump, line up dowel pin holes during assembly of adaptor to body. If installing new adaptor (which does not have predrilled dowel pin holes), install into bearing bore until it is bottomed firmly and use dowel pin holes in body to pilot drill dowel pin holes through adaptor, two places, 180 apart. Clean any brass chips from bearing area. Press roll pin into body to secure adaptor. Attach field coil to adaptor with three bolts and washers. Before assembling clutch pulley, turn body over and install seal assembly, wearplate cam and impeller as described in shaft seal and impeller replacement instructions. Complete assembly by installing gasket and end cover.

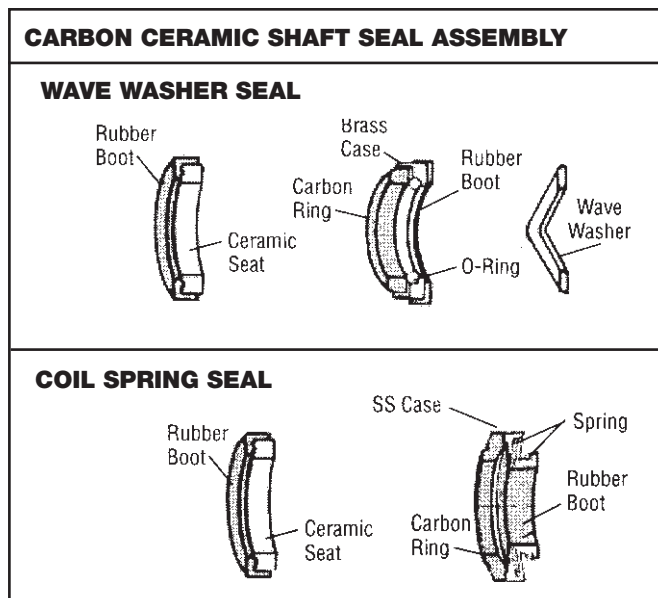

DIMENSIONAL DRAWING

Inches (millimeters)

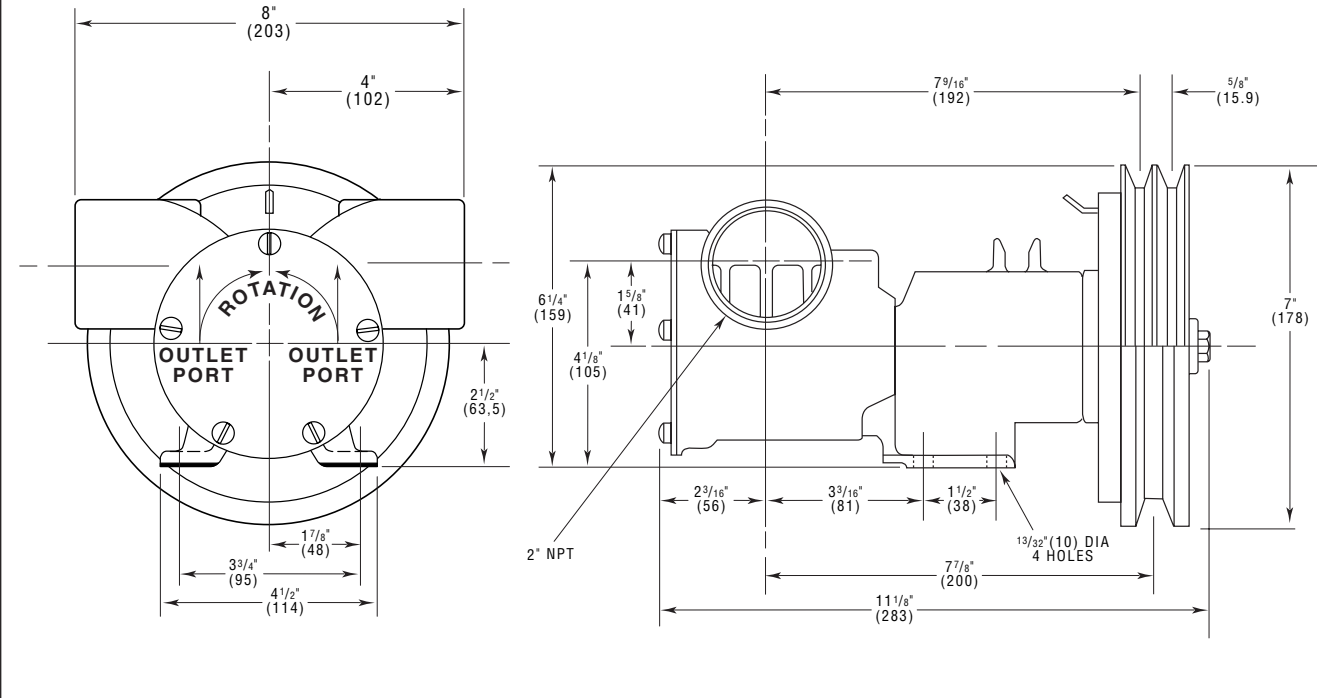

MODEL 18330-SERIES 2" PORTS HEAD CAPACITY TABLE

TOTAL HEAD				500 RPM			870 RPM			1180 RPM			1450 RPM			1750 RPM			2100 RPM			2450 RPM		
FT	kg/cm ²	Feet of Water	Meters of Water	GPM	l/min	HP	GPM	l/min	HP	GPM	l/min	HP	GPM	l/min	HP	GPM	l/min	HP	GPM	l/min	HP	GPM	l/min	HP
4.3	0.3	10	3.0	23	87	1/2	40	151	1	54	204	1	70	265	1-1/2	83	314	2	95	360	3	108	409	3
8.7	0.6	20	6.1	22	83	1/2	37	140	1	50	189	1	66	250	1-1/2	79	299	2	91	341	3	104	384	3
17.3	1.2	40	12.2	17	64	1/2	30	114	1	43	163	1-1/2	58	220	1-1/2	71	269	3	82	310	3	93	352	5
26.0	1.8	60	18.3	—	—	—	22	83	1-1/2	34	129	1-1/2	48	182	2	61	231	3	70	265	5	81	307	5
30.3	2.1	70	21.3	—	—	—	—	—	—	—	—	—	41	155	2	55	208	3	62	235	5	73	276	5

NOTE: Progressively longer life may be expected as operating pressures and speeds are reduced. Factory Application Engineering assistance suggested for operation in light shaded area and recommended for heavy shaded area. Table shows approximate Head-Flow for new pump in U.S. gallons per minute.



THE PRODUCTS DESCRIBED HEREIN ARE SUBJECT TO THE JABSCO ONE YEAR LIMITED WARRANTY, WHICH IS AVAILABLE FOR YOUR INSPECTION UPON REQUEST.

www.xylemflowcontrol.com

Jabco, 100 Cummings Center, Ste. 535-N, Beverly, MA 01915
Tel: +1 978 281 0440 Fax: +1 978 283 2619

USA

Jabco, Bingley Road, Hoddesdon, Hertfordshire, EN11 0BU
Tel: +44 (0) 1992 450 145 Fax: +44 (0) 1992 467 132

UK

NHK Jabco Co Ltd, 3-21-10, Shin - Yokohama Kohoku-ku, Yokohama 222
Tel: +81 (0) 45 475 8906 Fax: +81 (0) 45 475 8908

JAPAN

Jabco GmbH, Oststraße 28, 22844 Norderstedt
Tel: +49 (0) 40 53 53 73 0 Fax: +49 (0) 49 53 53 73 11

GERMANY

Jabco Italia, s.r.l., Via Tommaseo, 6, 20059 Vimercate, Milano
Tel: +39 039 685 2323 Fax: +39 039 666 307

ITALY

